

Paint Application

Paint is not a finished product until it has been applied and dried/cured on an appropriate substrate at the designed and specified film thickness. Proper application therefore is critical to the performance of the coating system. High performance paint systems are especially sensitive to misapplication and knowledge of the application characteristics and recommended film thickness is vital to obtain optimum results.

Three main application methods are used for applying the type of paints Transocean Coatings supplies. The choice between (airless) spray, brush or roller application depends on the type of coating to be applied, the total area to be covered, regulations and risk with regards to overspray and the availability of equipment and skilled operators.

Brush and Roller

Low viscosity paints are easily applied by these techniques to yield low applied film thickness. Modern, thixotropic paints are often specified at high film thickness especially where they perform a protective function. Therefore, where brush and roller methods are called upon (especially for "touching up" or "stripe coating") a number of coats may need to be applied in order to achieve the minimum specified dry film thickness. It is in general better to apply high solids paints by brush instead of roller.

Although these techniques have largely been replaced by spray application, they may find use in maintenance schedules operated by ship crews. Both methods have the advantage that paint losses are low but on the downside is the slow working speed.

Suggestions for good brush application:

1. Use of high quality, clean brushes of the proper shape and size will help achieve the best application.
2. Assure that all holidays or voids are eliminated, but avoid excessive brushing which may reduce film thickness and decrease protection.
3. Avoid filling the heel of the brush with material. Approximately half of the bristle length of the brush should be wet.
4. Stroke with the brush at 45° angle. Light strokes at this angle ensure even flow.
5. The brush application shall be by up and down strokes, then crosswise and finally with up and down strokes lightly. This is called cross lapping and helps eliminate brush and lap marks.

Fast drying materials often do not permit cross lapping which may cause paint to pile up. If it is necessary to brush apply fast dry material, it should be flowed on rapidly and generously and then left undisturbed. To go back over such a surface usually results in excessive brush drag, leaving ridges and brush marks.

Suggestions for effective roller application:

1. On large areas, material should be applied approximately on 0.75 sq. m. at a time.
2. Saturate the roller cover thoroughly with the coating. Paint should be loaded onto the cover until just before it drips.
3. The first strokes with the loaded roller should be done in a "W" pattern within approximately 0.75 sq. m area. The "W" pattern should then be fixed in with successive strokes.
4. Work from dry areas back into wet areas. In this way a more uniform film thickness is maintained.
5. When a material is applied to warm surfaces in direct sunlight or when fast drying coatings are used, work in smaller areas to maintain a wet edge.
6. Most coatings will dry to a slight orange peel appearance when applied by rollers.



Conventional Spray

This technique, sometimes called air-spray, mixes a jet of air with a stream of paint to propel a fan of paint droplets towards a surface. The mix of air with the paint particles gives high turbulence however and considerable "bounce back". Air atomisation of paint can thus result in considerable overspray.

Therefore, not only must adjacent areas be protected but also paint applicators must wear protection to avoid paint mist inhalation. The technique particularly suits low viscosity paints and most commonly used for the application of conventional decorative paints, certain types of finishes, zinc silicate and silicone (aluminium) heat resistant coatings.

Suggestions for effective air spray painting:

1. Use the lowest possible air and fluid pressure when operating a spray gun.
2. Use the proper fan width for the job.
3. Spray from the proper distance (6-10 inches).
4. Hold the gun perpendicular to the work throughout the spray stroke.
5. Move the spray gun parallel to the work surface throughout the spray stroke.
6. Move the spray gun at a speed which assures that a full wet coat is applied to the surface.
7. Overlap strokes at least 50%.

Air spray problems; patterns, cause and solution

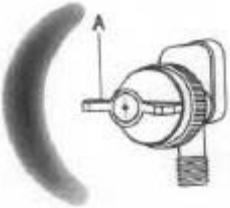
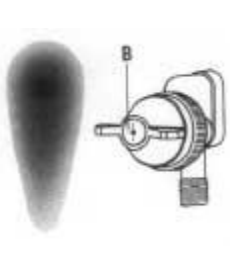
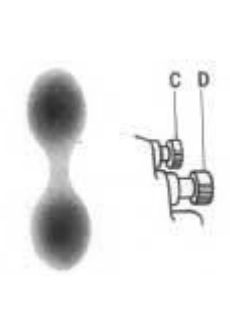
	<p>Cause: Dried material inside port "A" restricts passage of air through port on one side, results in full pressure of air from clean side of port in a fan pattern in direction of clogged side.</p> <p>Solution: Dissolve material inside the port with thinner. Do not use metal devices to probe into air nozzle openings.</p>
	<p>Cause: Dried material around the outside of the fluid nozzle tip at position "B" restricts the passage of atomizing air at one point through the centre ring opening of the air nozzle. This faulty pattern can also be caused by loose air nozzle or a bent fluid nozzle or needle tip.</p> <p>Solution: If dried material is causing the trouble, remove air nozzle and wipe off fluid tip using rag saturated with thinner. Tighten air nozzle. Replace fluid nozzle or needle if bent.</p>
	<p>Cause: A split spray pattern (heavy on each end of a fan pattern and weak in the middle) is usually caused by:</p> <ul style="list-style-type: none"> • Atomizing air pressure too high attempting to get too wide a spray with thin material • Not enough material available <p>Solution:</p> <ul style="list-style-type: none"> • Reduce air pressure • Open material control "D" to full position by turning to left. At the same time turn spray width adjustment "C" to right. This reduces width of spray but will correct split spray pattern.

(continued overleaf)

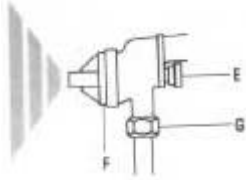
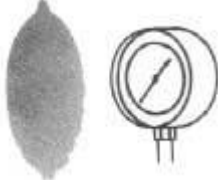

	<p>Cause: Air entering the fluid supply.</p> <ul style="list-style-type: none"> • Dried packing or missing packing around the material needle valve which permits air to get into fluid passageway. • Dirt between the fluid nozzle seat and body or a loosely installed fluid nozzle. • A loose or defective swivel nut, siphon cup or material hose. <p>Solution:</p> <ul style="list-style-type: none"> • Be sure all fittings and connections are tight. • Back up knurled ring "E". Place two drops of machine oil on packing. Replace nut and tighten. In more serious cases: replace packing.
	<p>Cause: A fan spray pattern that is hazy in the middle or a pattern that has an un-atomized "Salt and Pepper" effect indicates that the atomizing air pressure is not sufficiently high or there is too much material being fed to gun.</p> <p>Solution: Increase pressure from air supply. Correct air pressure as discussed elsewhere.</p>

Airless Spray

This technique relies on hydraulic pressure rather than air atomisation to produce the spray. Paint under very high pressures (1.000 to 6.000 p.s.i., approximately 100 to 400 kg/cm²) is delivered to the spray gun and then forced through a very small orifice to atomise it. Thus more rapid coverage can be achieved with much less overspray and considerably higher film thickness can be obtained.

Most paints manufactured by Transocean Coatings can be applied by airless spray. It has many advantages over conventional application methods such as a high output, reduced spray mist and less need for thinning.

Finally, it must be remembered that airless spray releases liquids under very high pressure. The spray gun should not be directed at people as injury can be easily caused and due precautions should be taken when the equipment is being cleaned.



Pressure

For airless spray, the pressure mention on the product datasheet may vary between 100 and 250bar (approx. 1450 – 3600psi) at the nozzle.

The type of pump to generate this pressure depends on several variables and generally the datasheet will not mention pump details: number of spray guns per pump, hose length, working height above the pump and viscosity of the paint material. Assuming an air input of 5-7 bar (approx. 70-100 psi), an pneumatic airless pump may need to be of the 20:1 to 50:1 ratio type with short hoses and minimal pressure loss to achieve the required nozzle pressure. In practice often 60:1 or 70:1 types are required on job site where long hoses are required.

The volume of air the compressor can generate is important to keep a steady input pressure. When large pumps are used (large volume and pressure ratio) and other (ventilation, mix and spray) equipment is feeding of the same air supply, this needs to be managed properly to prevent pressure drops during application as this may create paint defects such as sags and runs.

Nozzles size

Nozzles are normally identified by the numbers of their opening size and fan angle. Coding varies by supplier and colour coding may be used to further differentiate, tables are available to convert metric (mm) to imperial (mil). Larger opening sizes are generally used when spraying higher viscous (thicker) materials. Although material throughput (productivity) is higher, if too big an aperture is selected proper atomisation may be a problem, resulting in spattering, tailing and lack flow.



Fan angles are generally selected based on the shape of the item to be coated. Small angles are used for railings and (stripe) coating angles and supports. Larger angles create a wider covered area at the optimal spray distance. This can result in high material loss and overspray when coating complex structures.

Equipment suppliers often indicate the angle by the first digit in their nozzle code: a 517 nozzle has an angle of 50° and opening of 15 thou.

Below a simplified selection table for nozzle sizes is given and an illustration which indicates angle ranges.

'Thou' *	11	13	15	17	19	21	23	25	27	29	31	33	35	37
Inches	0.011	0.013	0.015	0.017	0.019	0.021	0.023	0.025	0.027	0.029	0.031	0.033	0.035	0.037
mm	0.28	0.33	0.38	0.43	0.48	0.53	0.58	0.64	0.69	0.74	0.79	0.84	0.89	0.94

* a 'thou' is $\frac{1}{1000}$ of an inch and often used as the size indicator on a nozzle

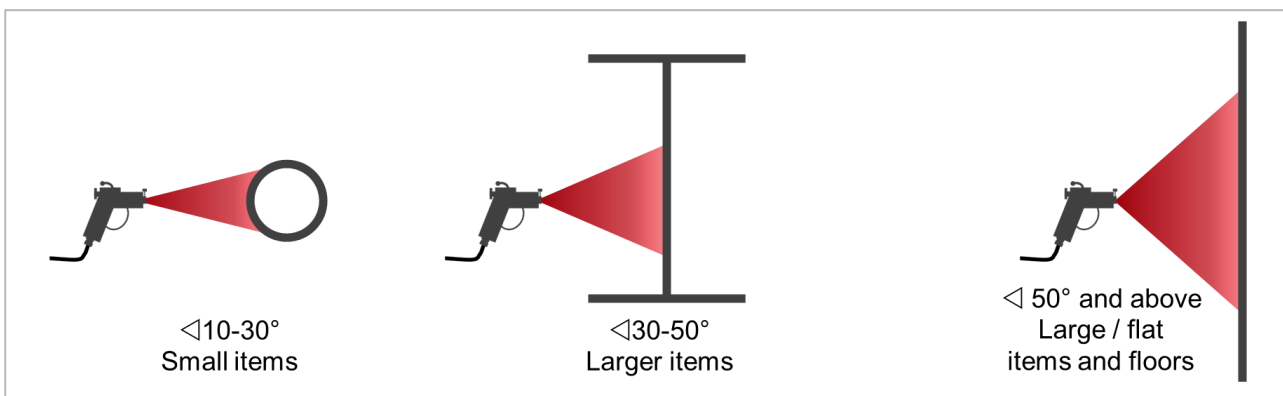
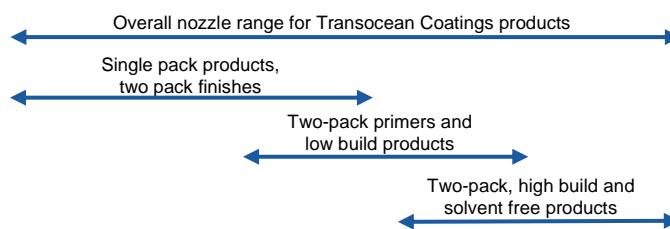





Suggestions for effective airless spray painting:

The technique employed for airless spraying is similar to the technique practiced in air spraying.

1. The ideal spraying pressure for any given tip is achieved by gradually increasing the pressure until the spray pattern appears uniform across its fan width and the atomized coating particles are of acceptable size.
2. If the coating is coarsely atomized, the pressure may be increased slightly, a smaller orifice tip used, or the coating thinned.
3. Avoid using excessively high airless spray pressures, which may cause effervescence or other finish defects.
4. Hold the gun perpendicular and move it parallel to the surface at all times in order to obtain a uniform coating of material.
5. Arcing, heeling and toeing should be avoided at all times.
6. The proper working distance with airless spray is approximately 10-15 inches (25-40cm).
7. When using wide angle spray tips, the gun must be moved closer (approx. 10-12 inches, 25-30cm) to the work. Excessive work distance increases paint fog/overspray and consumption.



Airless spray problems; patterns, cause and solution.

	<p>Cause: Inadequate fluid delivery, fluid not atomizing</p> <p>Solution:</p> <ul style="list-style-type: none"> • Increase fluid pressure • Change to a smaller tip orifice size • Reduce fluid viscosity • Clean gun and filters • Reduce number of guns using pump • Install a sapphire pre-orifice
	<p>Cause: Inadequate fluid delivery</p> <p>Solution:</p> <ul style="list-style-type: none"> • Increase fluid pressure • Change to larger tip orifice size • Reduce fluid viscosity (thinning, material temperature increase) • Clean gun and filters • Reduce number of guns using pump • Install a sapphire pre-orifice
	<p>Cause: Plugged or worn nozzle tip</p> <p>Solution: Clean or replace nozzle tip</p>
	<p>Cause: Pulsating fluid delivery suction leak</p> <p>Solution:</p> <ul style="list-style-type: none"> • Change to a smaller tip orifice size • Install pulsation chamber in system or drain existing one • Reduce number of guns using pump • Increase air supply to air motor • Remove restrictions in system. Clean tip screens or filters if used • Inspect for siphon hose leak
	<p>Cause:</p> <ul style="list-style-type: none"> • Worn tip • Fluid too heavy for tip <p>Solution:</p> <ul style="list-style-type: none"> • Replace tip • Increase pressure • Thin material • Change nozzle tip size



Spraying techniques

1. Movement of spray gun.

Coating should be even and wet when spraying

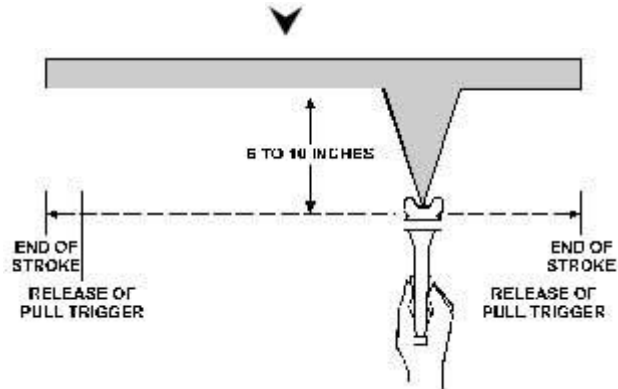

Right

Coating will be light at this point

Coating will be heavy at this point

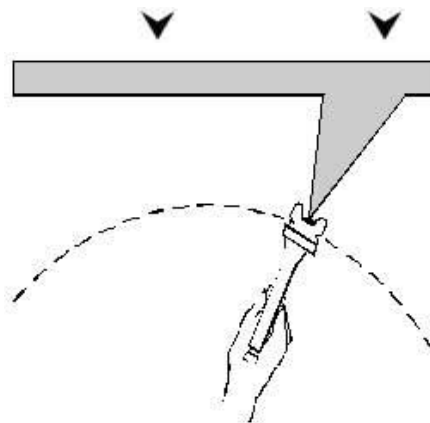

Wrong

2. Spray gun distance and angle to the surface

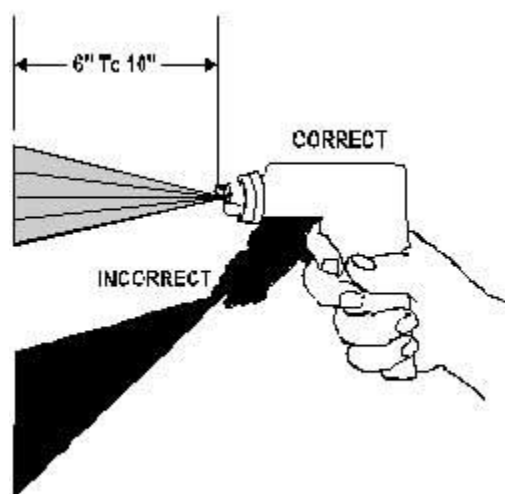

Hold the gun perpendicular to surface being sprayed



Impact of environmental and weather conditions

Bad weather conditions are a recurring hazard in ship painting operations especially during winter in moderate climates. At low temperatures (below 5°C), the curing of paints such as ordinary epoxies may slow down dramatically and for some paints stop altogether.

Others are not seriously affected and chlorinated rubber and vinyl paints may be used at or below 0°C as long as the surface is free from ice. Most paints will become thicker when temperature decreases and this effect may result in poor atomisation, dry spray and poor flow. The problem may be rectified by the addition of thinners but never more than the amount stated in the product datasheet.

Excessively high temperatures too may present problems. Generally, painting should be avoided during extremely hot hours - where paint operations are carried out in hot climates, the paint should be applied in the morning or early evening.

Paint should never be applied on wet surfaces and therefore painting is to avoid not only in rain, sleet and fog but also when high humidity and low steel temperatures lead to condensation. Condensation is very difficult to detect on surfaces and will occur if the steel temperature is below the atmospheric dew point.

As a general guide, application should not take place when the steel surface temperature is less than 3°C above the dew point.

Determination of dew point from ambient temperature and humidity.

Ambient temperature (°C).	Relative Humidity.								
	50%	55%	60%	65%	70%	75%	80%	85%	90%
6	-3,2	-2,1	-1,0	-0,1	0,9	1,8	2,8	3,7	4,5
8	-1,6	-0,4	0,8	1,8	2,8	3,8	4,7	5,6	6,5
10	0,1	1,3	2,6	3,7	4,7	5,6	6,7	7,6	8,4
11	1,0	2,3	3,5	4,6	5,6	6,6	7,6	8,6	9,4
12	1,9	3,2	4,5	5,6	6,6	7,6	8,6	9,6	10,4
13	2,8	4,2	5,4	6,6	7,6	8,6	9,6	10,6	11,4
14	3,7	5,1	6,4	7,5	8,6	9,6	10,6	11,5	12,4
15	4,7	6,1	7,3	8,5	9,5	10,6	11,5	12,5	13,4
16	5,6	7,0	8,3	9,5	10,5	11,6	12,5	13,5	14,4
17	6,5	7,9	9,2	10,4	11,5	12,5	13,5	14,5	15,3
18	7,4	8,8	10,2	11,4	12,4	13,5	14,5	15,4	16,3
19	8,3	9,7	11,1	12,3	13,4	14,5	15,5	16,4	17,3
20	9,3	10,7	12,0	13,3	14,4	15,4	16,4	17,4	18,3
22	11,1	12,5	13,8	15,2	16,3	17,4	18,4	19,4	20,3
24	12,9	14,4	15,7	17,0	18,2	19,3	20,3	21,3	22,3
26	14,8	16,2	17,6	18,8	20,1	21,2	22,3	23,3	24,2
28	16,6	18,1	19,5	20,8	22,0	23,2	24,2	25,2	26,2
30	18,4	20	21,4	22,7	23,9	25,1	26,2	27,2	28,2



Visibility

Finally, good visibility is important for the applicator to achieve a good control of the paint thickness and the quality of application. Therefore, painting should preferably be carried out during daylight. If necessary, artificial lighting can be put in place but should be strong enough and be able to reach all areas to be coated.

Paint handling and storage.

Apart from safety regulations, which must always be followed, storage instructions of the paints should be followed and conditions carefully controlled from their arrival at the store. Ambient temperature should never exceed the limit set by the technical sheets, and containers should not be in contact with humid surfaces, which might deteriorate them.

From the products' arrival, the production date should be checked at regular intervals, making sure not to exceed shelf life limits as specified on the sheet.

Containers should be regularly rotated, in order to always use the older one (first in/first out). Before use, paint should always be checked and thoroughly stirred until perfectly homogeneous from top to bottom, without different colour striations or marbling on the surface.

If stirring is done by hand instead of by mechanical stirrers, small quantities should be treated separately, afterwards such small amounts should be well mixed together. Paints should be sieved when clots or other alien materials are present.

When preparing two-pack paints, each component should be controlled and mixed separately. Both should be mixed together slowly and stirred until homogenous. It's advisable to use the entire content of the two-pack paint containers because they contain the exact dose required by the producer.

For two-component paint, only the amount that can be used within the pot-life limit should be prepared and in any case it's not advisable to miss too much of them, in order to avoid a too violent exothermic reaction caused by mixing that can solidify the product in the container.

Even when one other component is a powder, such as zinc in zinc-rich products, it's better to control the homogeneity of the fluid product, and then slowly mix the paint.

No solvent should be added unless it is specified by the producer's instructions. If paint has grown thick because it is cold, do not add any solvent, but bring the product to 15-30°C. If the thickened paint is a two-component product, add the catalyst in the first place, and the solvent only afterwards, if this is still necessary.

Hot paint should not be applied on cold steel; the best results are obtained when product and support are at the same temperature.



Application: Problem and solutions.

Application problems can originate from several causes or even from a combination of causes. An overview of typical problems experienced with paint application along with its causes and possible solutions is given in the table below.

Problem	Probable cause	Solution
Excessive spray fog	Excessive atomisation	Decrease pump pressure
	Too much thinner used	Do not add more thinner than necessary
	Distance spray gun to surface	The spray gun should be held at approx. 40 cm distance
Blistering	Contamination such as oil, grease and rust.	Degrease surface properly before painting
	Moisture	Ensure that substrate temperature is at least 3°C above dew point
"Orange peel"	Paint too thick	Add the correct amount of thinner.
	Paint too cold	Warm up the paint
Pinholes/ Cratering	Poor atomisation	Increase pump pressure
	Oil or grease on the surface	Degrease surface properly before painting
	Too high wet film thickness	Apply less paint by moving spray gun faster
Sagging	Spray gun distance to close	The spray gun should be held at approx. 40 cm distance
	Spray gun is held at a wrong angle to the surface	Spray gun should be held at a 90° angle to the surface and moved in a straight line
	Excessive wet film thickness	This can be caused by a less skilled painter or selection of a wrong nozzle
	Excessive dilution	Too much thinning always results in less efficient thixotropic properties. A paint should not be thinned more than necessary
Streaks or rat-tails	Nozzle can be worn out or too big	Select a new or smaller nozzle
	Paint too cold	Warm up the paint or increase pump pressure
	High viscosity of the paint	Use proper thinner or increase pump pressure
Dry overspray	Excessive atomisation	Decrease pump pressure
	Wrong nozzle (too small)	Use a larger nozzle
	Spray technique	Hold the spray gun closer to the surface and at the right angle.

